

Vibration Testing System "M" Series- II MPA712/M544A



CAT-MPA712/M544A-0611RevB



The "M" Series - II vibration testing system is ideal for screening of medium sized assemblies with high acceleration test requirements. The "M" Series - II also meets typical vibration test requirements of other medium to large sized electronic assemblies, automotive parts, aviation and avionics parts.

The "M" Series - II is designed to meet military and international test standards including MIL, ASTM, IEC, ISO, BS and JIS. A wide diameter armature with high cross axial stiffness will allow for using a proportioned head expander to test multiple specimens simultaneously yet achieving good vibration transmissibility ratio. Other test requirements including transportation vibration simulation, combined vibration-climatic test and seismic simulations for small size components can easily be fulfilled by the ETS "M" Series - II .

Features

- ◎ Rugged trunnion design with bearing guidance
- ◎ Air bag isolator built-in reducing dynamic floor stress
- ◎ Light weight composite armature coil for high acceleration performance
- ◎ Air load support for armature centering
- ◎ Dynamic and static armature centering available
- ◎ Roller-truss flexure suspension system with high cross axial stiffness

Benefits

- ◎ Simple system operation
- ◎ State-of-the-art microprocessor logic control unit
- ◎ High energy conversion efficiency (greater than 90%)
- ◎ Reasonable priced optimal performance system for major test standards
- ◎ Compact shaker and amplifier size saving valuable floor space
- ◎ Shaker air cooled by rugged outdoor blower for continuous long period operation
- ◎ Air cooled amplifier power electronics for safe and reliable operation
- ◎ Design to reduced reliance on mechanical switchgears with CPU logic controlled
- ◎ All-encompassing fuse protection designs for high current system components
- ◎ Detailed scope of system interlock protections
- ◎ Complies with USA, European and international safety and EMC regulations
- ◎ Compatible with any vibration controller
- ◎ Remote control panel available with full functional features
- ◎ Low profile body design ready for chamber integration
- ◎ Integration with unibase or standalone slip table
- ◎ Simple initial self system setup
- ◎ Interactive diagnostic 'System Status' displayed on LCD
- ◎ Easy maintenance and swift servicing
- ◎ Three years warranty on armature and field coil
- ◎ Worldwide spare parts support

No.8, Zijin South Road, National New Hi-Tech Industrial Park, Suzhou, Jiangsu, 215101, China
Tel: +86-512-66576316 Fax: +86-512-66576317
sales@etssolution.com www.etssolution.com

MPA712/M544A System Specification

System Model	MPA712/M544A
Sine Force	5,000 kgf
Random Force	5,000 kgf
Shock Force (6 ms, half sine)	10,000 kgf
Usable Frequency Range	DC~2,700 Hz
Maximum Displacement ①	51 mm
Maximum Velocity (Sine)	2 m/s
Maximum Acceleration (Sine)	981 m/s ²
Shaker Unit	M544A
Armature Diameter	445 mm
Effective Moving Element Mass	50 kg
Load Attachment Points	16 stainless steel inserts
Inserts Size (Standard)	M12
Grid Pattern (Diameter, Circle)	8 on Ø 203.2 mm; 8 on Ø 406.4 mm
First Resonance Frequency ②	2,100 Hz
Max. Static Payload	800 kg
Body Suspension Frequency	<5 Hz
Stray Flux Density ③	Less than 10 gauss
Dimension (Uncrated) (L x W x H)	1605 *1124 *1342 mm ³
Shaker Weight (Uncrated)	4,300 kg
Amplifier Unit	MPA712
Amplifier Output	60 kVA
Total Harmonic Distortion (At Rated Output)	From DC(0.1 Hz) to 500 Hz less than 0.5%; From 500Hz to 5,000 Hz less than 1.0%
Signal-Noise-Ratio	More than 65 dB at 100 V rms output, 10 K Ω input termination with rated resistive load
DC stability	Less than 0.05% of full output voltage with 10% change in line voltage.
Input Drive	1.5 V rms into 10 K Ohms for full output (120 V rms)
Amplifier Frequency response ④	From DC(0.1 Hz) to 2,000 Hz: \pm 1.5 dB; From DC(0.1 Hz) to 2,800 Hz: \pm 2.5 dB
Switching Frequency	112 kHz
Max. Output Voltage	120 V rms
Max. Output Current per module (Continuous)	50 A rms
Max. Output Current per module (Transient)	150 A rms
Amplifier Efficiency	> 90%
Dimension (Uncrated) (L x W x H)	550 *800 *2060 mm ³
Amplifier Weight (Uncrated)	800 kg
Blower Unit	HP- 4
Power Requirement	15 kW
Air Flow	1.36 m ³ /s
Air Pressure	0.075 kgf/cm ²
Dimension (Uncrated) (L x W x H)	1050 *897 *1970 mm ³
Weight (Uncrated)	290 kg

Remarks:

- ① Test payload should be less than 10% of shaker weight.
- ② Natural frequency at \pm 5% tolerance.
- ③ Measured at 152 mm above armature table. Contact us for lower gauss level requirement.
- ④ Sine mode, resistive load.

System Options

- Table Inserts (M10, 1/2"UNC, 3/8"UNC)
- Air Caster
- Air Isolation Feet
- Thermal Barrier
- Auxiliary Interlock Unit (AIU)
- Slip Table (Unibase or Stand Alone)
- Geared Aided Rotation (Chain Wheel Reducer)
- Head Expander
- Servo Control Console (SCC-1 Unit)
- Remote Control Panel (RCP)

M544A

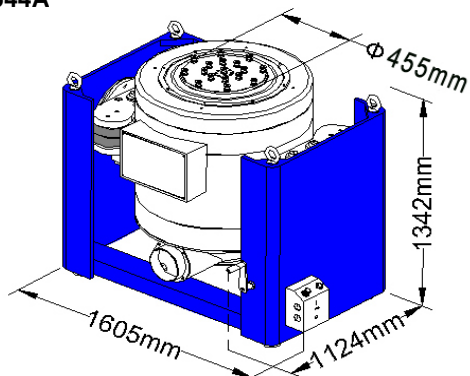

MPA712

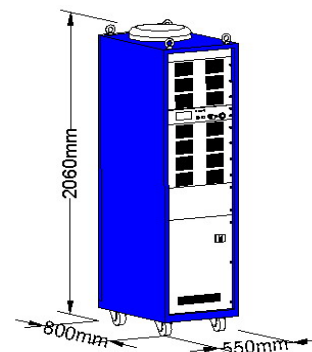

Specifications are correct at the time of publication. In keeping with our commitment to continuous product improvement, the information herewith is subject to change. ETS reserves the rights to amend specifications without prior notice.