

Shock Response Spectrum Analysis for ESS and STRIFE/HALT Measurement

by Stephen A. Smithson
Smithson & Associates, Minneapolis, MN

Biography

Steve Smithson earned a BSME from the University of Michigan in 1967 and an MBA from Arizona State University in 1975. He has been employed by Sperry and MTS Systems Corporations. Presently, he is an independent manufacturers' representative for Allegan Environmental Test Equipment, JC Systems, GHI Systems, Instrumented Sensor Technology, Hobbs Engineering Corporation and is a marketing consultant. He is a Senior Member of the IES and an ASQC member.

ABSTRACT

Traditional measurement, analysis and control of random vibration for ESS and accelerated life testing are based on acceleration spectral density (ASD). Test specifications, guidelines and documentation have become driven by controller and analyzer accuracies. Consequently, entire companies, programs, specifications and products are based upon the ASD. This inertia has caused the shortcomings of the ASD to be ignored in the face of tests and objectives for which peak accelerations are critical to evaluation of the test methods or product strength and to the success of the "test" itself.

A major rationale for the continued predominance of ASD is the perceived precision of control it allows, with implications that vibration tests are valid and repeatable because the input spectrum can be contoured to any desired shape and controlled. The emphasis in ESS (Environmental Stress Screening) or STRIFE (Stress + Life) test and HALT (Highly Accelerated Life Test), however, is to stimulate product to respond in all modes at levels and durations which bring to the surface workmanship, process or component flaws (ESS) and design flaws or marginalities (STRIFE or HALT).^{3,4} Correctly implemented, these applications are very result oriented.

Long an available tool for shock applications, Shock Response Spectrum (SRS) analysis offers a look at the product structure and response to shock-generated stimulus and is based on peak accelerations--accommodating non-coherent, non-stationary inputs which are 1) characteristic of 6 Degree of Freedom (DoF) impact-generated stimuli, and 2) necessary for a vibration stimulus to excite product weaknesses to hard failure or detectable intermittency via low cycle fatigue. SRS is perhaps the most valid evaluation method for the measurement of multi-axis broadband random vibration systems. Comparative SRS plots can be used to relate product operating and destruct (fragility) limits and the corresponding screen or test strengths.

INTRODUCTION

Since 1979, it has been very evident from the ESS Guidelines, Handbooks, published papers, government specifications, statements of work and vendor promotions, that there is "only one" or at least a predominant form of random excitation, and just a few acceptable variations of the ASD method upon which to measure, analyze and specify its use. Progress has been made with the shift in emphasis from specifying inputs to measuring responses, but there is now emphasis placed on quantifying these responses.¹ The responses at defect sites are not practically instrumented and thus their quantification is too global to be of value. The specific result desired is to bring to the surface design marginalities and manufacturing flaws by stimulating defect sites to response levels facilitating detection. Many key companion activities -- high rate thermal cycling, power on/off cycling, monitoring and corrective action -- are not being addressed in this paper.

Because electronics manufacturers recognize the United States Quality Crisis and are making efforts to survive and recover, uses for random vibration have developed from which **RESULTS**, not **COMPLIANCE**, are the objectives. In these applications, the proven 6 DoF broadband random vibration methods yield superior results, but are not covered by the ASD paradigm and therefore require a different set of rules.

The objective of this paper is to introduce and show validity of Shock Response Spectrum (SRS) analysis as a useful replacement paradigm which better applies to 6 DoF broadband excitation and, more broadly, for ESS and HALT/STRIFE applications.

The imperative for a replacement paradigm is based on the shortcomings of the old (existing ASD) methods, the physical behavior of electronic and electromechanical product to the 6 DoF excitation, and the objectives of the ESS and STRIFE/HALT applications. The balance of this paper presents these arguments.

TRENDS and DIRECTIONS

From the early 1980's, Hobbs' work with Chesney at IBM² and the work at numerous Hewlett-Packard Divisions set the course for design and reliability improvement techniques now followed by the leading commercial electronics manufacturers.^{3,4}

The implementation of ESS and STRIFE/HALT is not one of compliance, either with a requirement for the implementation of such a program or, more specifically, with any prescribed random vibration spectrum. The

objectives of these event-driven ESS and STRIFE/HALT processes are RESULTS, CORRECTIVE ACTION AND PREVENTION. The processes to achieve the objectives are empirical, iterative and require physically testing product to failure in order to expose weak links, identify root causes and implement corrective action. The author recommends that the reader become familiar with the advanced stress screening techniques that Hobbs has labelled HASS (Highly Accelerated Stress Screens)¹⁵ although the ESS acronym will be used throughout the balance of this paper for the sake of familiarity.

In ESS, it is acknowledged that some fatigue damage is accumulated on product with application of any stimulus. Not so universally acknowledged is that the manufacturer maintains the burden to prove that the screen regimen works, is rapid and cost effective -- all via "proof-of-screen" methods.^{3,4,6} The "proof of screen" must demonstrate the regimen can expose design marginalities or manufacturing defects that would occur in the field without breaking good product or consuming an unacceptably large portion of the product fatigue life.⁵ The mechanism of fatigue damage accumulation is the repeated application of a number of cycles where the peak-to-peak acceleration amplitude and the number of peaks at each amplitude are of prime importance. Using SRS helps focus on product responses to peak accelerations which are key to achieving results from vibration.

For HALT, or its subset STRIFE, there is every intention of doing physical damage to product enroute to maximizing and quantifying the margins of product strength (both operating and destruct) by stimulating above expected end-use environments.³ Common to both processes and critical to achieving results is that corrective action developed from failures must be fed back to design (STRIFE or HALT), manufacturing (ESS) or component process control, all designed to preclude recurrence of the failures.

ACCELERATION SPECTRAL DENSITY

Universally accepted as the standard for describing random vibration tests for acceleration-controlled electro-dynamic (E/D) shakers, acceleration spectral density is generated from an acceleration time history. From both its underlying theory and its application to real product responses however, the ASD has the following shortcomings:

1. In producing an ASD, the data are analyzed over time and averaged. The inherent assumption in the data is that the statistical properties do not change with time. The term stationarity is often used to define this property.

2. The ASD defines only the frequency distribution of the data and gives no measure of its amplitude distribution which is of

paramount importance in fatigue. We do not know if the ASD was generated from "near Gaussian" data with an approximate 3σ cut-off, or from highly non-linear data without any cut-off.

3. When data are generated from an ASD in the laboratory to drive an electro-dynamic (E/D) shaker, then typically only Gaussian data are reproduced.

4. Using the ASD, one knows neither input nor peak response.

As an example of 2 above, a time history of over-the-road data will contain the near steady state axle data but also data from expansions strips and the transient potholes. Analysis via ASD takes the averages, whereas the vehicle and sub-systems see environmental events (often 10 sigma higher than the average) not quantified by the ASD. The potholes, single events which excite the fundamental frequencies (f_n) of product modes, are capable of causing failure. These transients fall outside the definitional requirements of stationary data necessary to create the ASD.

Illustrating point 3 above are an original waveform or time history with high peak accelerations, (Figure 1.a), and its corresponding ASD, (Figure 1.b).

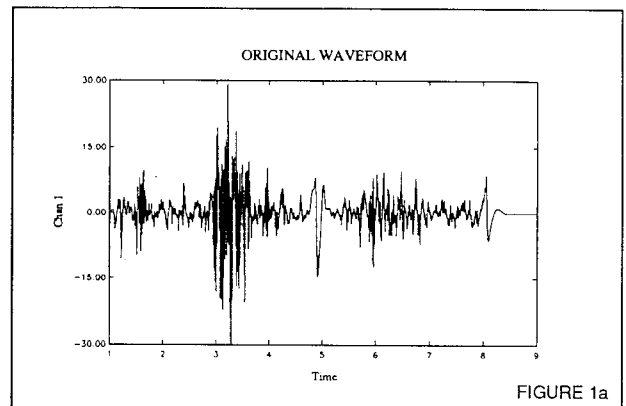

FIGURE 1a

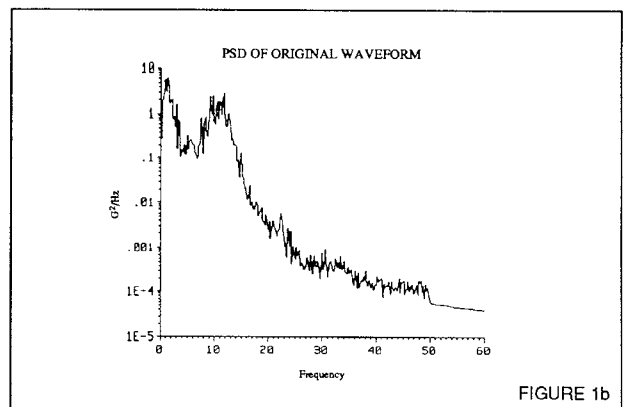

FIGURE 1b

Figure 1.c represents the time history regenerated in the lab via inverse FFT from the ASD (fig.1.b) for replay into the E/D shaker. Figure 1.d represents the ASD's for the both Figure 1.a and 1.c time histories.

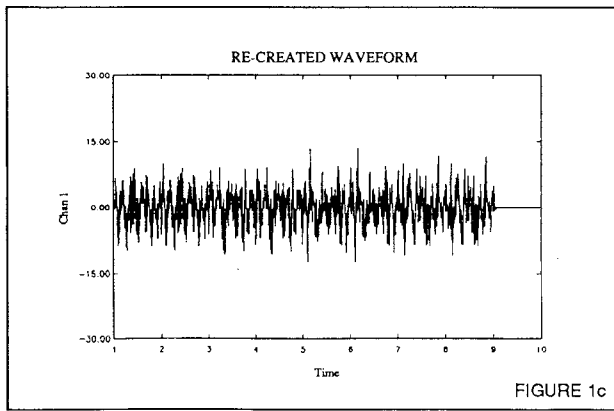

FIGURE 1c

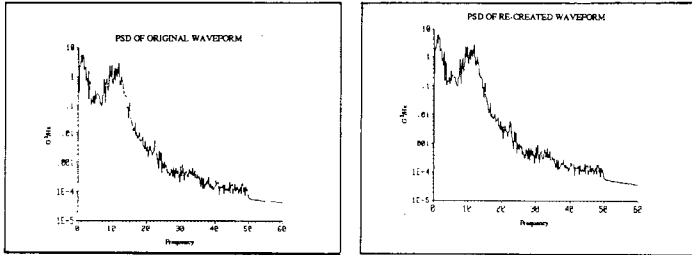

FIGURE 1d

Note the two ASD's are identical for the distinctly different time histories! It is clear that all GRMS are not created equal! Using the Figure 1.c time history, the high acceleration peaks, literally all the screen strength, would not be part of the vibration profile.

Lambert points out that "fatigue damage... is directly related to the level of vibration... and only indirectly related to the overall integrated vibration level, GRMS."⁸ From the standpoint of fatigue damage, controlling vibration using long-term ASD is not particularly relevant if the damage potential varies drastically for two ASD's with the same GRMS level. The Figure 1.c time history does not include the amplitudes capable of doing the required damage to defectives.

The ability to specify vibration input using the ASD carries a perceived repeatability based on this false precision. Despite industry tradition and familiarity with the ASD and E/D shakers, the "precision and repeatability" do not correlate to best results achievable in the ESS or HALT/STRIFE applications.

SHOCK RESPONSE SPECTRUM

The "Acceleration shock response spectrum can be regarded as the maximum acceleration responses to a given shock excitation of undamped mass-spring systems as a function of the frequencies of the systems."¹² For comprehensive tutorial information, the author directs the reader to References 7, 12, and 13.

The SRS is generated by passing the input and

product response acceleration time history through a complex algorithm (a ramp invariant recursive digital filter using over-sampled input) simulating the spring-mass systems which constitute the physical response structure of the device under test.

In electronic and electromechanical product the internal parts form more complicated systems than undamped systems, hence the response is characterized by spring-mass-damper model for an "infinite" number of frequencies. SRS plots are run for 5% critical damping typical of electronic hardware and systems. The damage potential, to be discussed in detail in a later section, is in general lower for damped systems than for undamped, particularly for multi-degree-of-freedom systems.¹²

The overlaid SRS of two vibration runs in Figure 2 clearly illustrates the reduced "Crest factor" and hence reduced damage potential resulting 2000 Hz low-pass filtering of a random input. This effect is not clearly evident from classical ASD analysis.

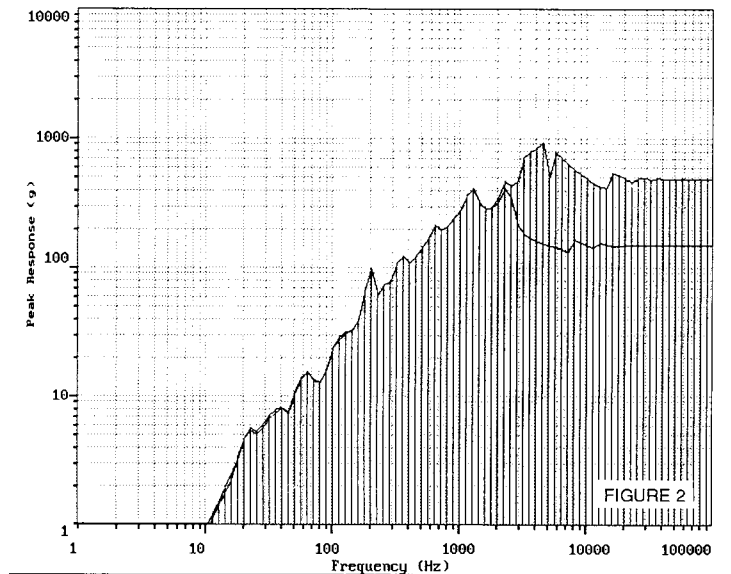

Channel Number= 1	Model = Acceleration
Damping = 0.05	Plot = 6th Oct. with Bars
Max Type = Maxi-Max	Samples from Memory

The common practices of 3 Sigma clipping necessary for control of traditional E/D exciters and further notching of input spectra are required to avoid overdriving modal resonances. These practices yield results similar to that that shown in Figure 2, a reduction of the peak accelerations responsible for many failures. Failures are ESS successes.

If there is any relationship between the determination of STRESS induced failure as a function of peak acceleration vs spectral frequency, it will only be measured with certainty with SRS.¹³

SIX DoF RANDOM VIBRATION

The vibration stimulus used by the leading ESS and HALT/STRIFE practitioners is the multi-axial (6 DoF), force-limited broadband

random. It is generated from the line spectra from multiple, out-of-phase pneumatic vibrators exciting either a modally rich/highly damped table or an extremely rigid table. Uniquely, and most critically, both excite all product response modes including rotations!

Not only is the 6 DoF excitation non-stationary (its frequency distribution varying constantly with time), but the product response to it is non-stationary and varying randomly in vector orientation as well. If one used a 1 Hz analysis band width at say, 437 Hz, over some small time interval, there might be no input excitation in phase with the 437 Hz natural frequency of a defective or non-defective element and thus the element responds as if to a transient and damps until excited again.

The ASD/narrowband control paradigm has failed to explain the anomaly of the successful 6 DoF excitation. That there is neither mathematical nor screen strength equivalence between the 6 DoF shakers and 1, 2, or 3 axis E/D shakers has been documented back to early 1983. Smith concluded that "only global defect yield is the appropriate measure".¹¹ Hobbs established that the excitation is truly 6 DoF showing the non-stationary "fuzzball", which proved the 3 linear and 3 rotational accelerations to be uncorrelated and non-coherent.⁹

The subject of control of 6 DoF pneumatic shakers must be clarified. The ASD paradigm is invalid for non-stationary signals and does not begin to accommodate simultaneous linear and rotational accelerations. The 6 DoF shakers have repeatedly demonstrated superior results on hardware despite failing all classical ASD criteria for control and contouring of spectra. Because of the ASD paradigm, those who implement vibration screens have come to expect a single parameter, GRMS to be the measure of an ASD, a test level or parameter to be controlled.

Air pressure to the pneumatic vibrators, vibration table response and product response directly determine the SRS, which, in turn, can be related to product strength and cumulative fatigue damage.

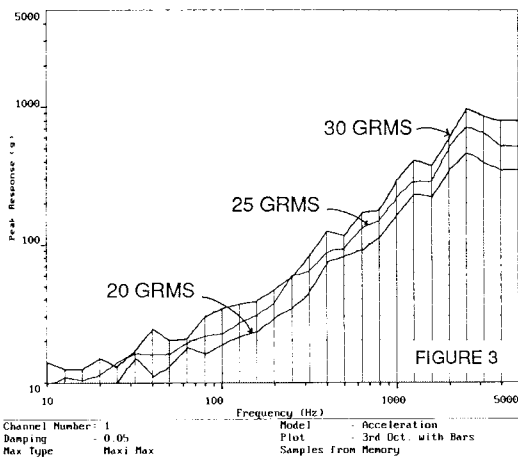

Figure 3 shows 3 SRS plots for bare table response of an OmniAxial™ (6 DoF) vibration system. As the normalized SRS is used to distinctly define shock pulse shapes,^{7,12,13} the identical SRS will result for shock pulse generated random vibration for the same air pressure, table and product. Closing the loop on GRMS, the shock response spectrum is repeatable.

REPLACING THE PARADIGM

Recommending a shift to the Shock Response Spectrum certainly does not constitute a complete substitute paradigm at this time, nor is it opening Pandora's Box. The SRS is both mathematically and practically valid for 6 DoF excitation and overcomes the shortcomings of the ASD.

Resistance to Change

There will continue to be challenges, but some of those prevailing to date disregard the objectives of ESS and HALT/STRIPE:

1. Most current efforts favor the predict and correlate approaches--predetermining or specifying the screen levels and durations (the ASD) in all vibration test applications.
2. Often the motivation has been simplification of the purchase specification or acquisition process.
3. Building hardware and dedicating it to ESS development is expensive. Minimizing this expense is a result of HALT⁴ and HASS¹⁵
4. The arguments offered against 6 DoF excitation center around demonstrating
 - a. controllability -- current practice is driven by instrumentation accuracies of +/- 3 db (or better) for input control while 6 DoF does not meet these control accuracies because of its non-stationary nature.
 - b. screen strength -- The question of "how much damage the screen regimen does" should be "how much product life is left?" This question is much easier to answer and should be imposed on classical methods as well.^{4,6}

These issues, and methods to develop answers have been and continue to be addressed by the leading users of 6 DoF excitation since the early-eighties.

Results

Failures of the classical vibration approaches that have had those shortcomings identified have often failed to call for physical proof on product.¹ The bottom line on results is the ability to reproduce on a 1 to 1 basis the field failures, design

attributable (HALT/STRIFE) or manufacturing process based (ESS).

Neither ASD nor SRS alone are a complete measure of screen/test strength. There is still "a gap in the derivation" to link any vibration measurement to screen strength (for ESS) or product strength (HALT/STRIFE). The strength of a regimen is a consequence of its effectiveness--exposing the flaws or design marginalities.

From many manufacturers who have been screening, there is consistent feedback that the most difficult defects to detect are intermittents. A critical indicator of effectiveness of a stimulus or regimen is its ability to repeatedly excite and facilitate detection of intermittent product performance. This critical ability must be determined empirically.¹⁶ Field returns classified as "no trouble found" are the best available units on which to prove effectiveness. Intermittents are not readily predictable from a statistical representation of random vibration input.

Rapid Fatigue Damage Accumulation

Efforts will and should continue to better quantify a stress screen or highly accelerated life test environment for predictive and test design purposes. There will also be the continuing need to correlate the fatigue damage done during a vibration screen or HALT/STRIFE to the product strength and, in turn, fatigue damage accumulated in the end-use environment.

Shock Response Spectra "give a useful measure of the damage potential of shocks" the maximum acceleration of all parts forming oscillatory systems of an equipment or component determines, in most cases, the maximum mechanical stress of their attachments and the maximum relative displacement of their elastic members; it is therefore directly related to several important causes of damage and failure due to the shock environment. One important effect to be noted is that the highest acceleration of the internal masses will be reached when resonances are excited" and "...that the greatest liability to damage in this respect will be when using short rise time pulses."¹²

For these reasons, the SRS can yield the parameters for implementation of Miner's Linear Cycle Damage Ratio Rule -- peak accelerations and number of cycles of applied stress.^{7,pg.23-20}

$$D_f = f_n T_r \frac{\sigma}{C} \frac{\beta}{\beta}$$

The exponent β is related to the slope of the S/N curve and ranges $8 < \beta < 12$. Therefore the influence of the ratio of applied stress (σ) at the defect site to the material strength (C) contributes to the cumulation of fatigue damage by a power of 10 more than the duration or number of applications of a stress.⁸ Note that because of stress

concentrations and residual stresses, σ is higher and C lower for defective elements in a structure.

The above expression for Miner's Rule must be expanded by summation to reflect stresses and responses at all frequencies (f_n) of a product and of all modes excited by the 6 DoF stimulus.

The relationship between SRS and cumulative fatigue damage was discussed by Caruso and Szymkowiak in the context of using random vibration as an equivalent to MIL-STD-810D/E shock test requirements.¹⁴ The SRS was the more appropriate tool for the comparison. They further stressed that the higher acceleration $>3\sigma$ peaks do most damage, but compared only single axis, E/D shaker-generated random with shock tests of only 6 peak-response cycles. The 6 DoF shakers provide more continuous excitation than traditional shock and provide the "friendly", yet comprehensive environment in which to expose intermittents.

The defective elements can fail in Low Cycle Fatigue subjected to high peak accelerations in contrast to both non-defective and defective elements being at risk to High Cycle Fatigue failure from the less damaging (more tightly controlled) mean stresses that do not produce results in short enough vibration times, T_r .

The development of the number of cycles of stress application ($f_n \times T_r$) at any f_n yields the distribution in Figure 4, indicating the number of cycles exceeding the peak response values indicated on the abscissa for that given frequency.^{7,pg.23-20}

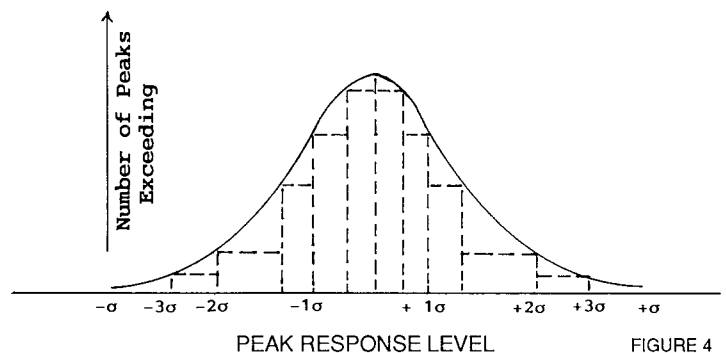

The "number of peaks exceeding" and number of cycles at each frequency are available from the digitized time histories of each axis of response measured. Each frequency represents a mode in a given degree of freedom and hence a sub-structure responding whether defective or non-defective.

An alternate presentation, Figure 5 is the 3 dimensional SRS showing the surface described by the parallel "number of peaks exceeding" distributions along the frequency axis of the 2 dimensional SRS plane as shown in Figure 4 above.

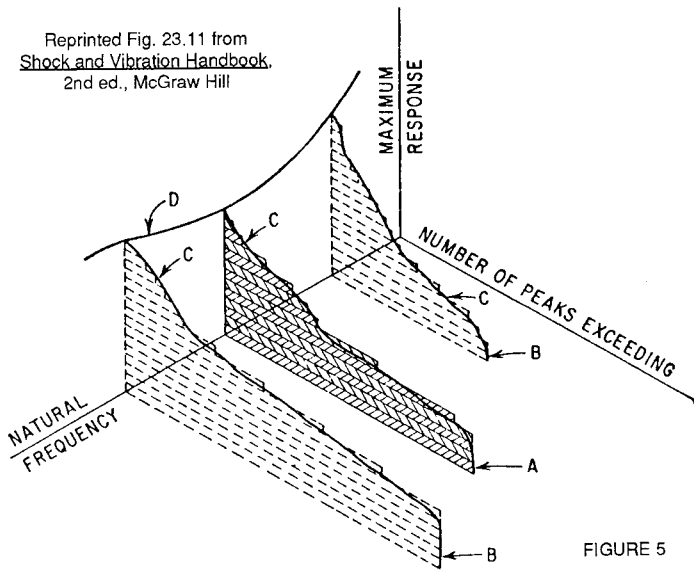

FIGURE 5

Note that each point on the surface described in Figure 5 represents a peak acceleration and, proportional to the vibration duration, other cycles of "less-than-peak" amplitude also contribute to the cumulative fatigue damage. An expansion of Miner's Rule by summation would have to incorporate "less-than-peak amplitudes" and vibration duration at each natural frequency.

Quantification of cumulative fatigue damage becomes possible, but may involve the "volume" under the surface representing the distribution of amplitudes over time for each frequency, mode and degree of freedom. This process could be complex, time consuming and costly, and, in contrast with advanced screen development methods, may be the far slower path to useable results.^{4,15,16} Nonetheless, far more information is available from the SRS approach than from the ASD. Results remain dependent on vibrating the product to determine what actually fails.

CONCLUSIONS AND RECOMMENDATIONS

Conclusions

1. The SRS is the replacement paradigm for the ASD for 6-DoF excitation:
 - a. Identification of new methods of measurement and analysis for multi-axis shakers
 - b. Quantifying excitation levels, product strength and fragility distributions for ESS and HALT/STRIFE applications.
2. Because the ASD is invalid for the effective 6 DoF vibration, resistance should evaporate ceasing to block progress.
3. This paper has identified that valuable information is available from SRS that is valid for ESS and HALT/STRIFE applications and meets the objectives better than possible with ASD.

Recommendations

Further investigation should be directed toward clarifying whether or not the following areas have potential as expansions and further validation of the proposed SRS paradigm:

1. Exploit SRS as an analysis tool --
 - a. Investigate 6 DoF SRS, including tri-axial and rotations
 - b. Separate out the bare table and fixture contribution and analyze the net SRS of product under test.
2. The data (time history) and methods exist to count peaks and cycles at different acceleration levels (related to stress) gives the basis for estimation of cumulative fatigue damage via Miner's rule:
 - a. Fatigue damage for given vibration screen duration -- Because the SRS is based on product response to random peak acceleration as a function of frequency, two screens producing the same SRS and distribution of accelerations at each frequency should be an indication of the same amount of damage.
 - b. Shaker vs. shaker screen strength and fatigue damage comparison on product, powered and monitored for detection of intermittents.
3. Tolerance bars -- just as shock machines are characterized using SRS,¹³ a 6 DoF table will have the same SRS at a given pneumatic pressure and payload. Since the SRS analysis lends itself to tolerance bar limits, vibration table check-out and go/no-go comparisons are feasible to demonstrate repeatable performance.
4. Fatigue damage vs. product strength and life -- See APPENDIX
 - a. End-use environment
 - b. ESS
 - c. HALT/STRIFE
 - d. Qualification/Validation Tests
 - e. Extended Life/RDGT -- Reliability Demo and Growth
5. The mechanisms 6 DoF broadband excitation should be documented by qualified dynamicists for Shock & Vibration Handbook -- at a minimum for the ESS and HALT/STRIFE applications, and via SRS methods.
6. Learning from the experience of the 1979 to 1990 period, there should be no rush to satisfy the "cookbook urge" to develop SRS specifications for ESS and STRIFE/HALT which are inherently (and most successful as) event-driven, adaptable, feedback-generating processes.

ACKNOWLEDGEMENTS

The author wishes to acknowledge the valued contributions of the following:

Dr. Colin J. Dodds, EG&G -- Structural Kinematics, Detroit, MI
 Robert Fiedler, Robert Fiedler & Associates, Minneapolis, MN
 Chet Haibel, Hewlett-Packard, Boise, ID
 George R. Henderson, GHI Systems, San Pedro, CA
 Dr. Gregg K. Hobbs, Hobbs Engineering Corporation, Westminster, CO
 Charles Schinner, Hewlett-Packard, San Diego, CA

REFERENCES

1. Institute of Environmental Sciences, Environmental Stress Screening Guidelines for Assemblies, ESSEH Committee, Appendix B, March 1990.
2. Chesney, Kenneth E., Step Stress Analysis of a Printer, Proceedings of the Reliability and Maintainability Seminar, Las Vegas, Nevada, 28-30 January, 1986.
3. Hobbs, G.K., Highly Accelerated Life Tests--HALT, unpublished, contained in seminar notes, SCREENING TECHNOLOGY, copyright April 1990.
4. Hobbs, G.K., Modern Methods in Stress Screening, unpublished, contained in seminar notes, SCREENING TECHNOLOGY, copyright January 1991.
5. Smithson, S.A., Effectiveness and Economics--Yardsticks for ESS Decisions, 1990 Proceedings, Institute of Environmental Sciences, pgs. 737-742.
6. Hobbs, G.K., Evaluation of Stress Screens, 1988 Proceedings Institute of Environmental Sciences. pgs. 47-49.
7. Harris, Cyril M. and Crede, Charles E., Shock & Vibration Handbook, 3rd edition, McGraw-Hill 1988.
8. Lambert, R.G., Case Histories of Selection Criteria for Random Vibration Screening, The Journal of the Environmental Sciences, Jan/Feb 1985, pgs. 19-25.
9. Hobbs, G.K. and Mercado, R., Six Degree of Freedom Vibration Stress Screening, The Journal of Environmental Sciences, Nov/Dec 1984, pgs. 46-53.
10. Nolan, P.J., Real Time Road Data Simulation for Vibration Testing, "Bringing the Road into the Laboratory", Presented at the National Safe Transit Conference 1990, May 9, 1990.
11. Smith, L.G., Comparison of Pneumatic Exciter and Electrodynamic Exciter Test Severity, Interdepartmental Memo, Hughes Aircraft Company, April 7, 1983.
12. Basic Environmental Testing Procedures, Publication 68-2-27, Shock Spectra and Other Characteristics of Pulse Shapes, Bureau de la Commission Electronique, Geneva, Switzerland, 1972, Appendix A, Pgs. 17-37.
13. Henderson, G.R., Standardization of Shock Machines using SRS Analysis, unpublished, copyright 1991.
14. Caruso, H.J. and Szymkowiak, E., A Clarification of the Shock/Vibration Equivalence in MIL-STD-810D/E, The Journal of Environmental Sciences, Sept/Oct 1989.
15. Hobbs, G.K., Highly Accelerated Stress Screens -- HASS, unpublished, contained in seminar notes, SCREENING TECHNOLOGY, copyright April 1989.
16. Hobbs, G.K., Precipitation and Detection Screens, unpublished, contained in seminar notes, SCREENING TECHNOLOGY, copyright February 1990.

APPENDIX -- POTENTIAL APPLICATION

The Highly Accelerated Life Test (HALT) methods developed by Hobbs address design marginalities, robust designs, screen development including HASS, proof of screen and pave the way for significant, well-documented competitive and economic benefits.^{3,4,15} The underlying approach is the step stress method applied to product first with individual stresses and then with combinations of stresses. Figure 6 showing three SRS levels (borrowed from Figure 3) represents the step stress progression of the HALT process for vibration. Only the top

half of the step stress graphic is shown and is used for vibration, high temperature, temperature rate of change, upper levels for power and clock frequency variation, and for other stimuli found to be effective. The lower half mirrors the top and would be used for low temperature, etc.

SRS Test Report

GHI SYSTEMS, INC. TRIAD CAT SYSTEM

Date : Sat Jan 26 1991 Test Engineer : G. Henderson
 Customer : Allegan Env. Product Tested: Bare Table
 Type of Test : SRS Calibration RMS Command : 30 g's

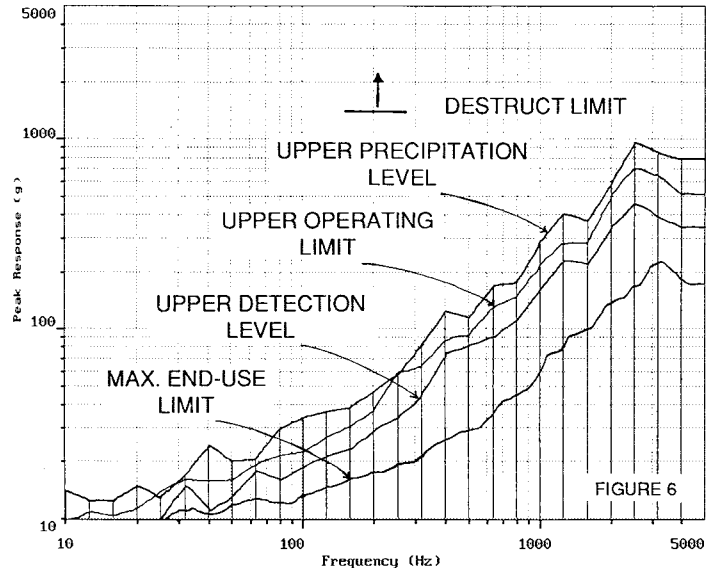

Channel Number= 1 Model = Acceleration
 Damping = 0.05 Plot = 3rd Oct. with Bars
 Max Type = Maxi-Max Samples from Memory

Three of the SRS plots are labelled to illustrate the end-use, detection and precipitation levels to which the product is excited. The operating limit SRS (labelled) and destruct limit represent responses or product strengths which are distributions. Using the step stress techniques to determine the levels and limits (tails of the strength distributions), weak links can be precipitated and corrected. Using proof of screen techniques to verify the levels and limits, a HALT and HASS documentation tool might be developed. Application of tolerance bars might prove feasible.